



# FILTERCHARGER® INJECTION PERFORMANCE KIT

## INSTALLATION INSTRUCTIONS

### 57-2505-1

**Ford/Mercury  
Thunderbird/Cougar  
1991-97 V6-3.8L (non-S.C)  
1991-93 V8-5.0L  
1994-97 V8-4.6L**

#### TOOLS NEEDED:

- |                        |                  |
|------------------------|------------------|
| Flat blade screwdriver | 10mm socket      |
| pair of Dykes          | 11mm socket      |
| ratchet                | 7/16" wrench     |
| socket extension       | 5mm allen wrench |
| 5/16" socket           | drill            |
| 7/16" socket           | 1/4" drill bit   |

#### TO START:

1. Turn the ignition OFF and disconnect the vehicle's negative battery cable.



2. Disconnect the mass air sensor and the air temperature sensor electrical connections. **NOTE:** Not all vehicles are equipped with an air temperature sensor.



3. Loosen the hose clamp and remove the intake tube at the mass air sensor.



4. Release the over center clips on the airbox and remove the airbox lid from the vehicle.



5. Using a 7/16" socket, loosen and remove the three nuts that secure the airbox base. **NOTE:** the factory nuts will not be reused.



6. Remove the airbox base as shown.

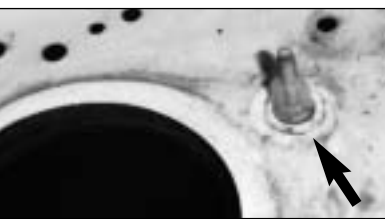

7. Using a pair of dykes, cut the three plastic clips from the airbox mounting studs.

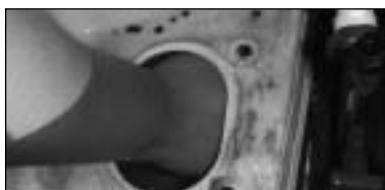

8. Once you have cut the clips from the mounting studs, push the scoop down into the cavity to remove the three threaded clips from the studs.

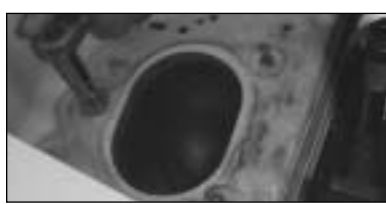

9. Assemble the hardware provided onto the two front mounting studs, as shown above in the illustration.



10. Remove the mass air sensor from the airbox lid.



11. Remove the air temperature sensor from the airbox lid. **NOTE:** Not all vehicles are equipped with an air temperature sensor.



12. Attach the "Z" bracket and temperature sensor bracket onto the mass air sensor, secure with the hardware provided as shown. **NOTE:** Some vehicle's are equipped with a threaded or a push-in style air temperature sensor. Use appropriate bracket supplied.



13. On models equipped with a push-in style air temperature sensor, apply the temperature sensor gasket provided to the temperature sensor bracket.



14. Insert the air temperature sensor into the slotted hole on the air temperature sensor bracket and turn 90 degrees to secure. **NOTE:** On models equipped with a threaded style air temperature sensor, push the air temperature sensor through the hole in the temperature sensor bracket and secure it with the provided nut.

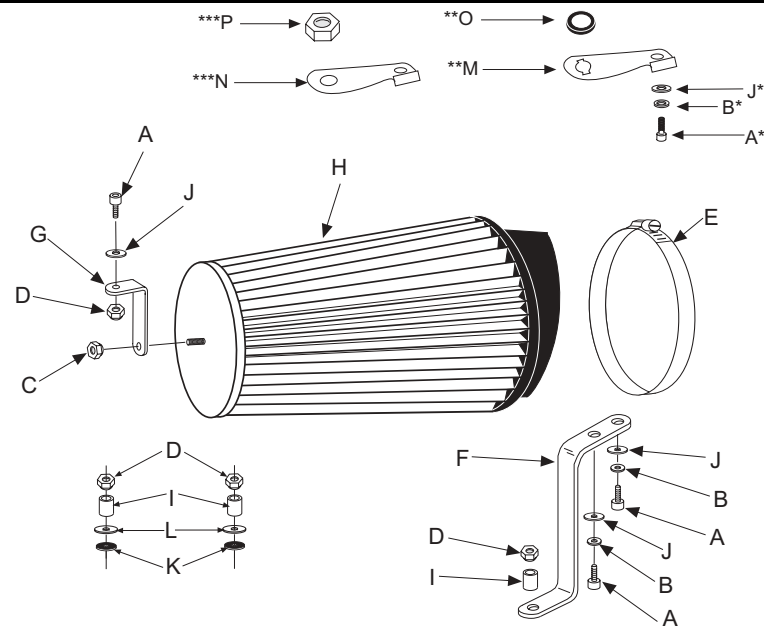

#### PARTS LIST:

A	6mm allen bolt, 16mm long	4
B	6mm wave washer	3
C	1/4"-20 nylock nut	1
D	6mm nylock nut	4
E	Hose clamp #56	1
F	"Z" bracket	1
G	"L" bracket	1
H	Filtercharger® element	1
I	Spacer	3
J	Flat washer	4
K	Rubber washer	2
L	Fender washer	2
M	Temp. sensor bracket (slotted hole)	1
N	Temp. sensor bracket	1
O	Temp. sensor gasket	1
P	3/8" NPT locknut	1

\* These items are to be utilized for models equipped with an Air Temperature sensor.

\*\* These items are to be used for models equipped with a push-in style Air Temperature sensor.

\*\*\* These items are to be used for models equipped with a threaded-style Air Temperature sensor.



15. Insert the mass air assembly into the intake tube and secure with original hose clamp.



16. Place the "Z" bracket onto the original rear airbox mounting stud and secure it with the hardware provided.



17. Attach the "L" bracket to the stud located on the top plate of the filtercharger element, secure with provided nut.



18. Install the filtercharger element onto the mass air sensor as shown.



19. Line up the "L" bracket with the radiator core support. Position everything for best fit and clearance. Mark the "L" bracket hole, then remove the filtercharger and drill.



20. Reinstall the filtercharger element onto the mass air sensor and secure with the hose clamp provided. Line up the "L" bracket with the hole drilled in the previous step and secure it with the hardware provided.



21. Reconnect the mass air sensor and the air temperature sensor electrical connections.

22. Reconnect the vehicle's negative battery cable. Double check to make sure everything is tight and properly positioned before starting the vehicle.

23. The C.A.R.B. exemption sticker, (attached), must be visible under the hood, so that an emissions inspector can see it when the vehicle is required to be tested for emissions. California requires testing every two years, other states may vary.

24. It will be necessary for all FIPK's to be checked periodically for realignment, clearance and tightening of all connections. Failure to follow the above instructions or proper maintenance may void warranty.

#### ROAD TESTING:

1. Start the engine with the transmission in neutral or park, and the parking brake engaged. Listen for air leaks or odd noises. For air leaks secure hoses and connections. For odd noises, find cause and repair before proceeding. This kit will function identically to the factory system except for being louder and much more responsive.

2. Test drive the vehicle. Listen for odd noises or rattles and fix as necessary.

3. If road test is fine, you can now enjoy the added power and performance from your kit.

4. K&N suggests checking the Filtercharger element periodically for excessive dirt build-up. When the element becomes covered in dirt (or once a year), service it according to the instructions on the Recharger service kit that is included in this kit.



P.O. BOX 1329, RIVERSIDE, CA, 92502 USA  
JOHN ST., WARRINGTON, CHESHIRE WA2 7UB ENGLAND

(909) 684-9762 FAX (909) 684-0716 TECH: (800) 858-3333  
WWW: <http://KNFilters.com> e-mail: [Tech@KNFilters.com](mailto:Tech@KNFilters.com)