



FILTERCHARGER[®]

INJECTION PERFORMANCE KIT

INSTALLATION INSTRUCTIONS

57-2513-1

Ford/Mercury

1995-97 Ranger, Explorer V6-4.0L OHV

***1996-97 Explorer V8-5.0L**

***1997 Mountaineer V8-5.0L**

- NOTE -

This kit was not designed for vehicles with body lifts.

* Only applicable on vehicles equipped with FA 1641 cylindrical style filter.

TOOLS NEEDED:

- 5/16" wrench
- vise grips
- Flat blade screwdriver
- 10mm wrench
- 5mm allen wrench

TO START:

1. Turn the ignition OFF and disconnect the vehicle's negative battery cable.



2. Loosen the hose clamp at the airbox.



3. Using a flat blade screwdriver, remove the push clip.



4. Disconnect the secondary mass air sensor electrical connection.



5. Detach the intake tube from the airbox.



6. Pull firmly up on airbox to release airbox from grommets on lower airbox support bracket assembly.



7. Pull rubber boot back away from airbox. Depress tab with screwdriver as shown to release electrical connection.



8. Using a flat blade screwdriver, depress tabs on cover to remove mass air sensor.



9. Loosen and remove the nuts from the mass air sensor. **NOTE:** It may be necessary to use vise grips to secure studs.



10. Remove the lower airbox support bracket from fender well.



11. Remove the grommets from lower airbox support bracket.



12. Using the hardware provided, assemble the mass air adapter, gasket and brackets as shown in illustration above.



PARTS LIST:

A	Flat washer	4	G	Support bracket	2
B	6mm-1.00 x 20mm allen bolt	2	H	Mass Air Adapter	1
C	6mm-1.00 x 25mm allen bolt	4	J	Gasket	1
D	6mm-1.00 nylock nut	6	K	Intake adapter	1
E	Hose clamp #104	1	L	Filtercharger [®] element	1
F	Mass Air Bracket	2	M	Cable tie	1

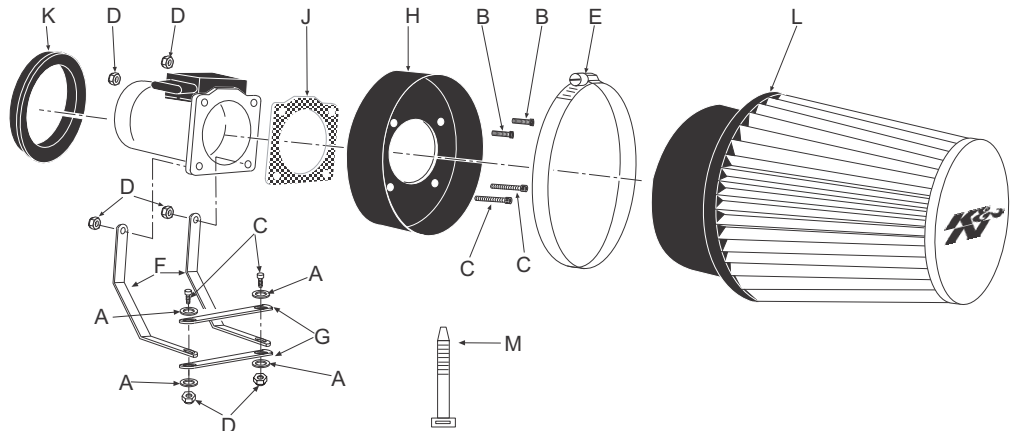

13. Using the hardware and support brackets provided, attach the mass air assembly to the airbox support bracket.



14. Using a 5/16" wrench, reinstall the mass air assembly into the fender using the original hardware.



15. Install rubber intake adapter onto mass air sensor.



16. Reinstall the intake tube over the rubber intake adapter. Using a flatblade screwdriver tighten the hose clamp.



17. Install Filtercharger element onto mass air adapter and secure with the provided hose clamp.



18. Reconnect the secondary mass air sensor electrical connection. **NOTE:** use the provided cable tie to secure the slack.



19. Reconnect the primary mass air sensor electrical connection.

20. Reconnect the vehicle's negative battery cable. Double check to make sure everything is tight and properly positioned before starting the vehicle.

21. The C.A.R.B. exemption sticker, (attached), must be visible under the hood, so that an emissions inspector can see it when the vehicle is required to be tested for emissions. California requires testing every two years, other states may vary.

22. It will be necessary for all FIPK's to be checked periodically for realignment, clearance and tightening of all connections. Failure to follow the above instructions or proper maintenance may void warranty.

ROAD TESTING:

1. Start the engine with the transmission in neutral or park, and the parking brake engaged. Listen for air leaks or odd noises. For air leaks secure hoses and connections. For odd noises, find cause and repair before proceeding. This kit will function identically to the factory system except for being louder and much more responsive.

2. Test drive the vehicle. Listen for odd noises or rattles and fix as necessary.

3. If road test is fine, you can now enjoy the added power and performance from your kit.

4. K&N suggests checking the Filtercharger element periodically for excessive dirt build-up. When the element becomes covered in dirt (or once a year), service it according to the instructions on the Recharger service kit that is included in this kit.



P.O. BOX 1329, RIVERSIDE, CA, 92502 USA
JOHN ST., WARRINGTON, CHESHIRE WA2 7UB ENGLAND

(909) 684-9762 FAX (909) 684-0716 TECH: (800) 858-3333
e-mail: tech@knfilters.com WWW: <http://www.knfilters.com>
17802a