

# TYPHOON INTAKE SYSTEMS®

BY 

## INSTALLATION INSTRUCTIONS

### 69-3511

Ford

2002-04 Focus SVT  
L4-2.0L DOHC

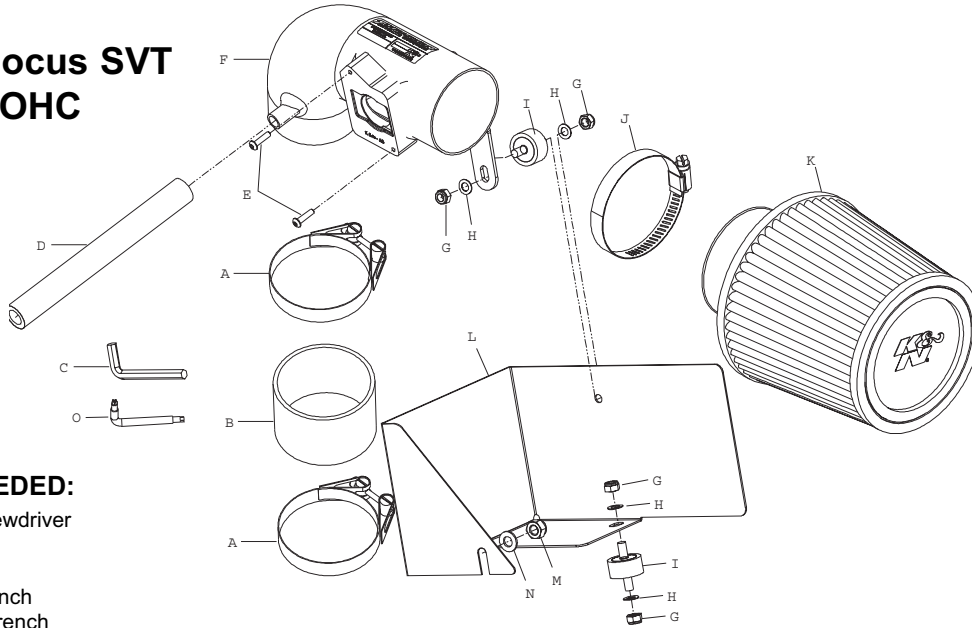

#### TOOLS NEEDED:

Flat Blade Screwdriver  
Ratchet  
10mm socket  
13mm end wrench  
2.5mm Allen wrench  
T20 Torx driver

#### Parts List

	Description	Qty.	P/N
A	HOSE CLAMP #300V, BARREL, SS	2	084062
B	HOSE; 2-3/4"ID X 2", BLUE	1	08196
B	HOSE; 2-3/4"ID X 2", BLACK	1	08440
C	WRENCH; 9/64 ALLEN KEY	1	69802
D	HOSE; 1/2"ID X 7"L, BLACK SILICONE	1	08159
E	BOLT; M4-0.7X 16MM, CHA, SS	2	07793
F	TYPHOON TUBE	1	27139TB
G	NUT; 6MM NYLOCK, SS	4	07512
H	WASHER; 6MM WAVE, SS	4	08277
I	STUD; RUBBER MOUNT 6MM	2	07027
J	HOSE CLAMP #44	1	08577
K	FILTERCHARGER	1	KRU4960E
L	HEAT SHIELD; 69-3511	1	07304
M	NUT; 8MM NYLOCK, SS	1	07502
N	WASHER; 8MM FLAT, SS	1	08272
O	WRENCH; TORX T-20 L-KEY	1	69801

\* You will receive one blue or one black silicone hose depending on the color of kit ordered.

#### TO START:

1. Turn the ignition OFF and disconnect the vehicle's negative battery cable.



2. Disconnect the mass air sensor electrical connection as shown.



3. Pull up firmly to remove the plastic throttle linkage cover as shown.



4. Pull up firmly to remove the plastic coil cover as shown.



5. Disconnect the crank case vent hose from the cam cover as shown.



6. Remove the clamp at the throttle body as shown.



7. Pull firmly upwards to remove the air cleaner assembly as shown.



8. Remove the rubber bumper from the air cleaner tray as shown.



9. Install the provided nut and washer onto the stock bolt on the air cleaner tray as shown.



10. Install the rubber mounted stud onto the battery tray and secure with the provided hardware as shown.

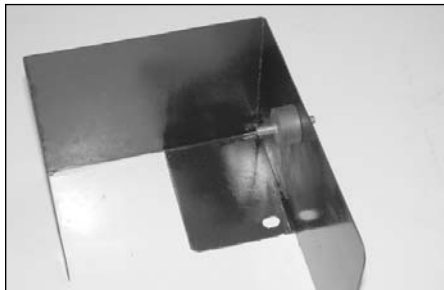

11. Install the rubber mounted stud onto the heat shield and secure it with the provided hardware as shown.

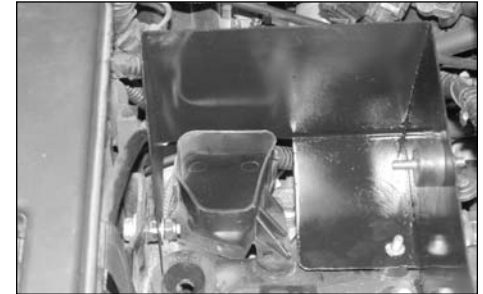

12. Install the heat shield into the vehicle and slide the slot on the heat shield onto the bolt from step 9, then, line up the hole with the rubber mounted stud from step 10 as shown.



13. Secure the heat shield to the rubber mounted stud using the provided hardware as shown.



14. Tighten the hex nut on the heat shield as shown.



15. Remove the mass air sensor from the stock air cleaner assembly as shown using the provided Torx wrench.



16. Install the silicone hose and hose clamps onto the K&N Typhoon intake tube as shown.



17. Install the provided silicone hose onto the vent on the K&N Typhoon intake tube as shown.



18. Install the mass air sensor into the tube and secure with the provided hardware as shown.



19. Install the tube into the vehicle and onto the throttle body as shown.



20. Line up the tube bracket with the rubber mounted stud and secure with the provided hardware as shown.



21. Install the Filtercharger onto the Typhoon intake tube and tighten as shown.



22. Adjust for best fit and clearance and tighten all hardware as shown.

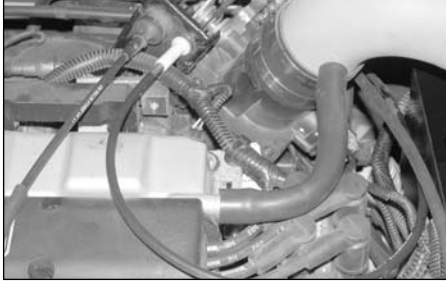

23. Reconnect the crank case vent hose to the cam cover as shown.



24. Reconnect the mass air sensor electrical connection as shown.

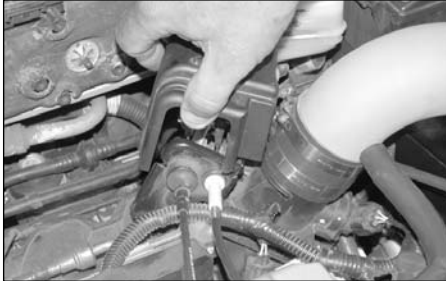

25. Reinstall the plastic throttle linkage cover as shown.



26. Reinstall the plastic coil cover as shown.



27. Reconnect the negative battery cable and double check to make sure everything is tightened and properly positioned before starting the vehicle.

28. The C.A.R.B. exemption sticker, (attached), must be visible under the hood, so that an emissions inspector can see it when the vehicle is required to be tested for emissions. California requires testing every two years, other states may vary.

29. It will be necessary for all Typhoons to be checked periodically for realignment, clearance and tightening of all connections. Failure to follow the above instructions or proper maintenance may void warranty.

#### ROAD TESTING:

1. Start the engine with the transmission in neutral or park, and the parking brake engaged. Listen for air leaks or odd noises. For air leaks secure hoses and connections. For odd noises, find cause and repair before proceeding. This kit will function identically to the factory system except for being louder and much more responsive.

2. Test drive the vehicle. Listen for odd noises or rattles and fix as necessary.

3. If road test is fine, you can now enjoy the added power and performance from your kit.

4. K&N suggests checking the Filtercharger element periodically for excessive dirt build-up. When the element becomes covered in dirt (or once a year), service it according to the instructions on the Recharger service kit, part number 99-5000 or 99-5050.