

INSTALLATION INSTRUCTIONS

77-1526

Jeep
1999-03 Grand Cherokee
L6-4.0L

NOTE: This kit was not designed to fit vehicles with a body lift

TOOLS NEEDED:

Flat Blade Screwdriver
7/16" Wrench
5/8" Wrench
10mm Socket
13mm Socket/7/16" Socket
Ratchet w/long extension

TO START:

1. Turn the ignition OFF and disconnect the vehicle's negative battery cable.



2. Disconnect the crank case vent hose as shown.



3. Loosen the bolt on the resonator as shown.



4. Loosen the hose clamp at the air cleaner lid and at the throttle body, then, remove the resonator and bellows assembly as shown.



5. Remove the three nuts that secure the air cleaner assembly from underneath the vehicle, then, remove the air cleaner assembly as shown.



6. Install the provided trim seal onto the heat shield as shown. Trim if needed.

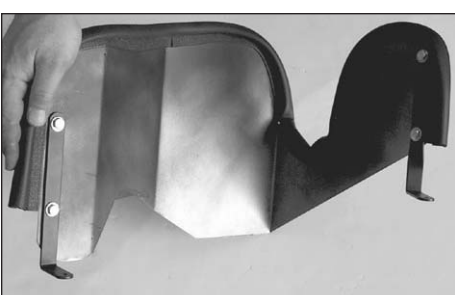

7. Using the provided hardware install the two brackets onto the heat shield as shown.

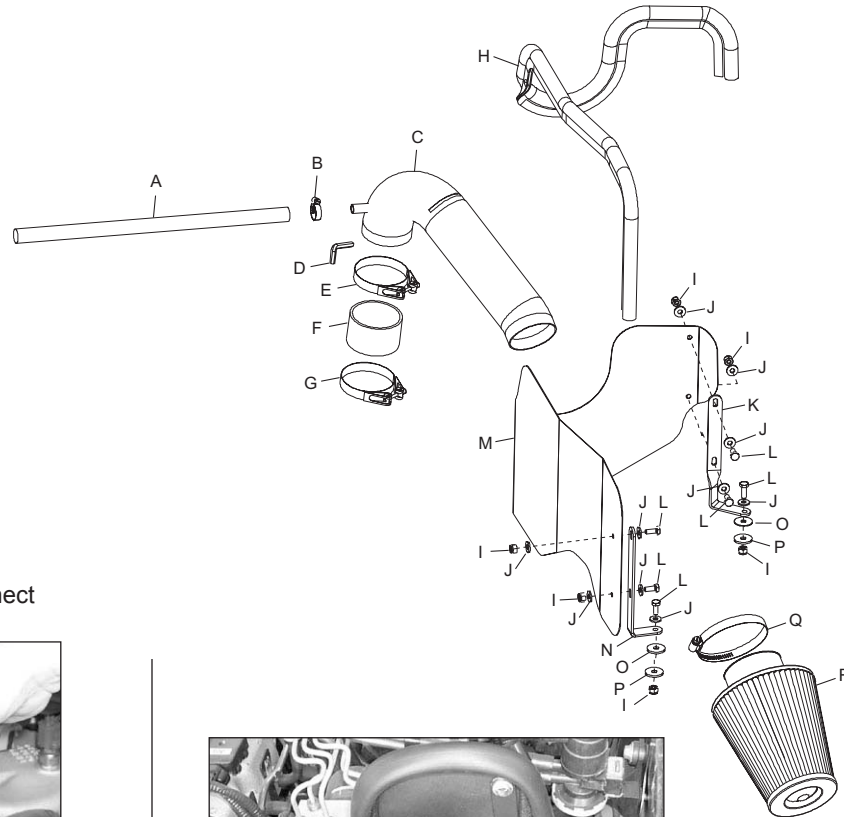

8. Install the heat shield into the vehicle and secure the twist bracket to the original air cleaner mounting hole using the provided hardware.

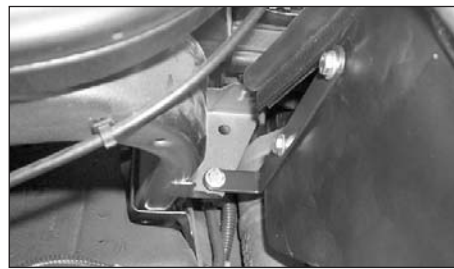

9. Secure the "L" bracket to the hole on the flange/tab on the radiator core support using the provided hardware.



10. Install the provided silicone hose and hose clamps onto the throttle body as shown.



11. Install the K&N intake tube into the silicone hose as shown, but do not tighten completely as some adjustment may be necessary.



12. Connect the provided hose to the vent on the valve cover, then, connect the other end to the vent on the K&N intake tube as shown.

PARTS LIST:

Description	Qty.	P/N
A Silicone Hose, 1/2"ID x 15-3/4"L.	1	08414
B Hose Clamp, #6 Mini	1	08407
C Intake Tube	1	27423
D Wrench, 9/64" Allen	1	69802
E Hose Clamp, #275	1	084061
F Silicone Step Hose	1	084014
G Hose Clamp, #300	1	084062
H Edge Trim, 3/4" bulb, 48"L	1	102485
I Nut, 6mm Nylock	6	07512
J Washer, 6mm Flat, SS	10	08269
K Bracket, "L" Twist	1	070912
L Bolt, M6-1.00 x 20mm L, Hex	6	07795
M Heat Shield	1	07475
N Bracket, "L"	1	070902
O Washer, Rubber	2	21685
P Washer, Fender	2	08160
Q Hose Clamp, #44	1	08577
R Filtercharger	1	RU-4870



13. Install the K&N Filtercharger onto the K&N intake tube and secure with the provided hose clamp.



14. Reconnect the vehicle's negative battery cable. Double check to make sure everything is tight and properly positioned before starting the vehicle.

15. It will be necessary for all Performance Intake Kit's to be checked periodically for realignment, clearance and tightening of all connections. Failure to follow the above instructions or proper maintenance may void warranty.

ROAD TESTING:

1. Start the engine with the transmission in neutral or park, and the parking brake engaged. Listen for air leaks or odd noises. For air leaks secure hoses and connections. For odd noises, find cause and repair before proceeding. This kit will function identically to the factory system except for being louder and much more responsive.
2. Test drive the vehicle. Listen for odd noises or rattles and fix as necessary.
3. If road test is fine, you can now enjoy the added power and performance from your kit.
4. K&N suggests checking the Filtercharger element periodically for excessive dirt build-up. When the element becomes covered in dirt (or once a year), service it according to the instructions on the Recharger service kit, part number 99-5050 or 99-5000.

FREE K&N DECAL To register your warranty, please see us online at knfilters.com/register. FREE K&N DECAL