

INSTALLATION INSTRUCTIONS

**77-9023
TOYOTA
2003-06 4RUNNER
V6-4.0L**

NOTE: This kit was not designed to fit vehicles with a body lift.

TOOLS NEEDED:

- Ratchet
- Extension
- 10mm Socket
- 12mm Socket
- 13mm Socket
- Phillips Screwdriver
- 2.5mm Allen
- 9/64" Allen Wrench
- Pliers

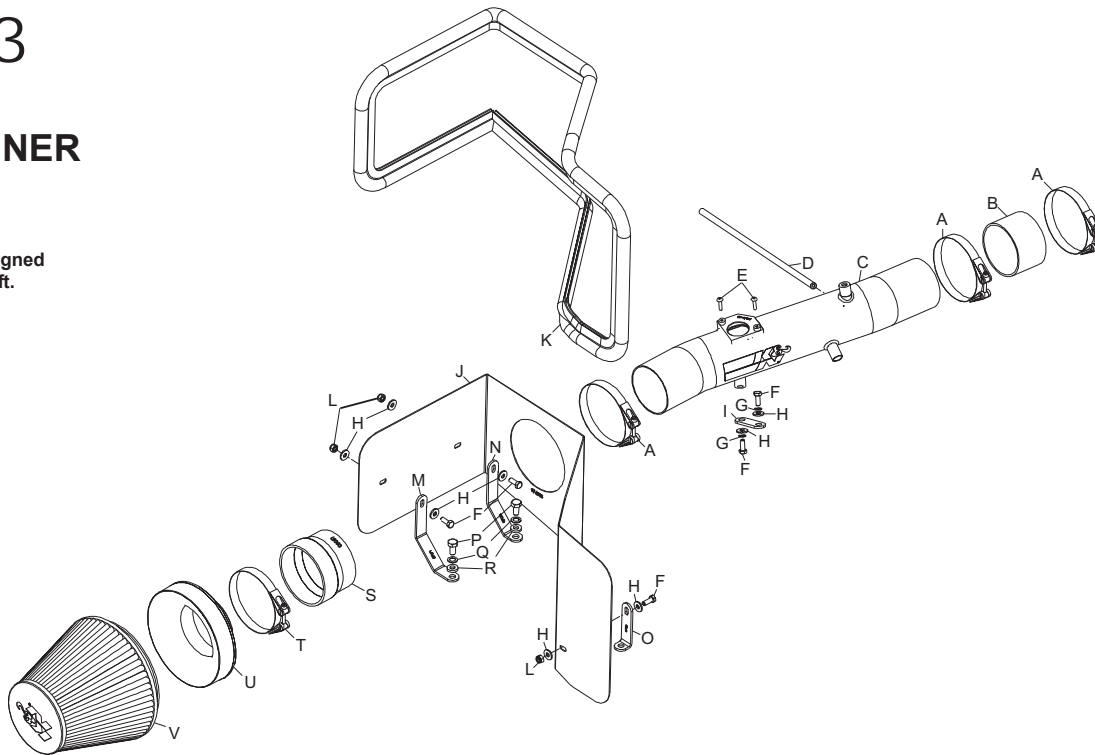

PARTS LIST:

| Desc. | Qty. | Part# |
|---|------|---------|
| A hose clamp; #325, barrel | 3 | 084063 |
| B hose; 3"ID X 2"L, BLACK | 1 | 08434 |
| C intake tube | 1 | 27418 |
| D silicone hose, 4mm X 18" long | 1 | 08153 |
| E bolt; m4-.7 X 16mm button head allen | 2 | 07793 |
| F bolt; 6mm-1.00 X 16mm | 5 | 07703 |
| G washer; 1/4" split lock | 2 | 08198 |
| H washer; 1/4" id X 5/8" od flat | 8 | 08275 |
| I bracket; straight | 1 | 07133 |
| J heat shield | 1 | 074005 |
| K edge trim 83" | 1 | 102503 |
| L nut; 6mm nylock | 3 | 07553 |
| M bracket, long (L) | 1 | 07171 |
| N bracket, medium (L) | 1 | 07172 |
| O bracket (L) | 1 | 07158 |
| P bolt; 8mm X 1.25 X 16mm | 2 | 07844 |
| Q washer; 8mm wave | 2 | 08239 |
| R washer; 5/16" id X 5/8" od flat | 2 | 08276 |
| S hose; 3" TO 3-1/2" X 3"L, trpd, black | 1 | 084055 |
| T hose clamp; #375, barrel | 1 | 084065 |
| U adapter; #380 | 1 | 21512 |
| V filter charger | 1 | RF-1048 |

TO START:

1. Turn the ignition OFF and disconnect the vehicle's negative battery cable.

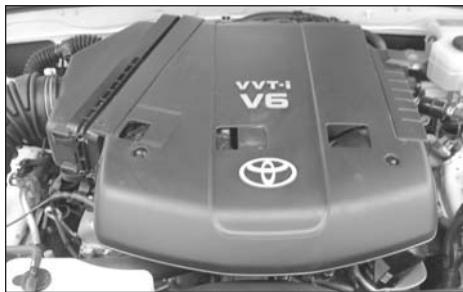

2. Loosen the two nuts that secure the engine cover, then remove the engine cover

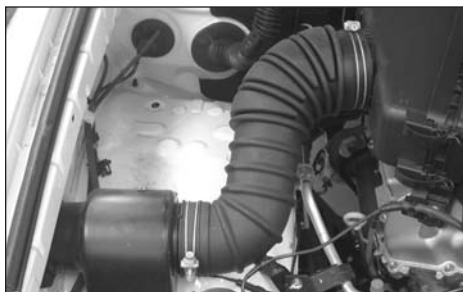

3. Loosen the hose clamps at the air box and resonator.



4. Pull wire harness clip up to release from intake tube.



5. Remove intake tube from vehicle as shown.



6. Remove two bolts that secure resonator to inner fender, then remove resonator from vehicle as shown.



7. Disconnect the two mass air wire harness retaining clips from air box, then disconnect the mass air sensor electrical connection.



8. Remove crank case vent hose from air box as shown.



9. Remove fuel pressure regulator hose from back side of air box.

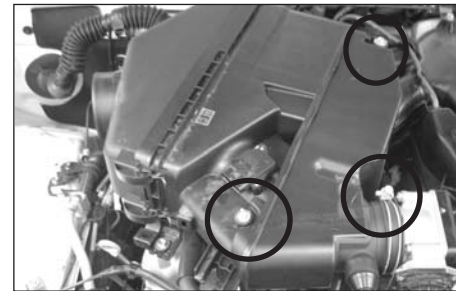

10. Loosen the hose clamp at throttle body, then remove the two bolts that secure air box to engine.



11. Remove air box assembly from engine as shown.

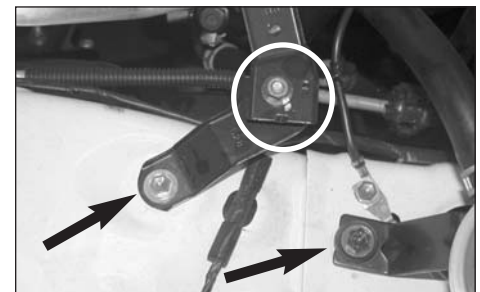

12. Remove the two bolts and loosen nut as shown.



13. Rotate bracket onto power steering reservoir, then secure with bolt removed in previous step, then retighten nut and bolt.



14. Remove the 12mm bolt that retains the power steering reserve to vehicle, then mount the provided bracket (070632) onto the vehicle with the bolt that was removed.



15. Mount the two provided brackets onto the vehicle with the provided hardware.

NOTE: Bracket (07172) mounts closest to engine.



16. Install the edge trim onto the heat shield as shown. Trim if needed.



17. Install the heat shield onto the vehicle, then secure to brackets with the provided hardware.

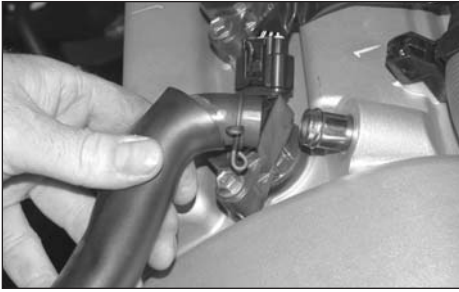

18. Remove crank case vent hose from valve cover.

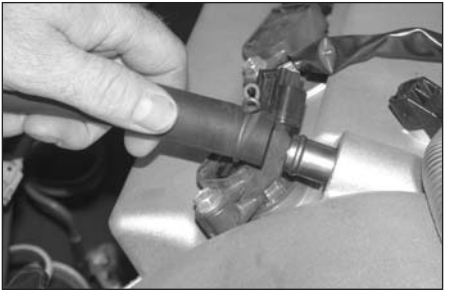

19. Flip the crank case vent hose around and reconnect the opposite end of the hose to the valve cover.



20. Install the provided silicone hose (084340) onto the throttle body with the provided hose clamps.



21. Remove the two screws that secure the mass air sensor to the air box assembly, then remove the mass air sensor as shown.



22. Secure the mass air sensor to the K&N intake tube using the provided screws as shown.

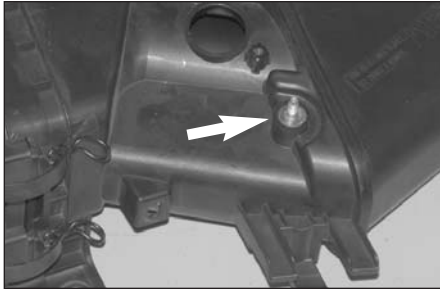

23. Remove the engine cover mounting stud shown from the factory air box.

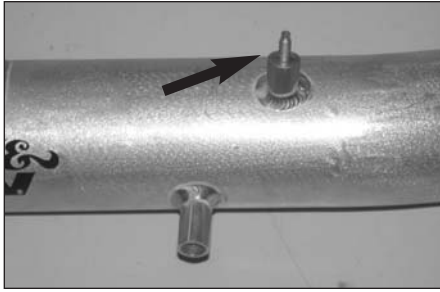

24. Install the stud removed in step #23 into the threaded boss on the K&N intake tube as shown.



25. Install the tube mounting bracket (07133) onto the K&N intake tube as shown.

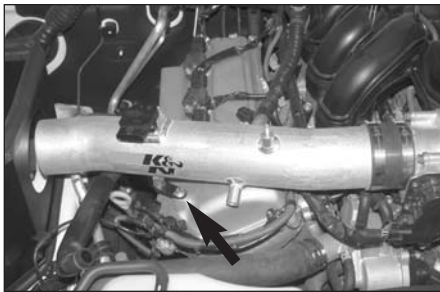

26. Install the K&N intake tube onto the throttle body and align the mounting bracket with the threaded boss on the engine valve cover then secure with the provided hardware and hose clamp.

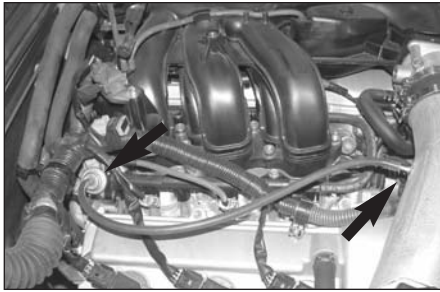

27. Remove the stock vacuum hose from fuel pressure regulator, then install provided silicone hose to fuel pressure regulator and then onto the K&N intake tube.



28. Connect the factory crank case vent hose onto the K&N intake tube as shown.



29. Install the filter adapter into the Filtercharger as shown and secure with the provided hose clamp.

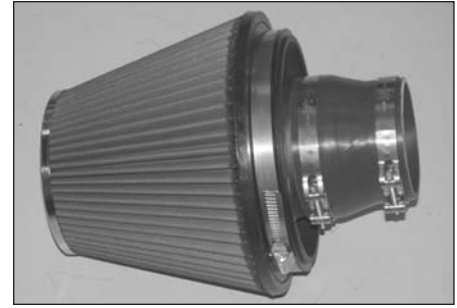

30. Install the provided silicone hose (084055) onto the filter adapter and secure with the provided hose clamp as shown.

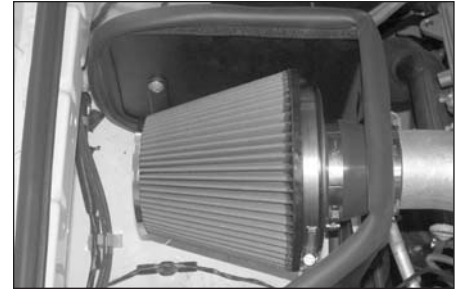

31. Install the Filtercharger assembly onto the k&N intake tube and secure with the provided hose clamp.

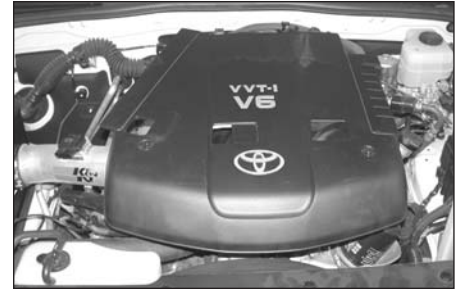

32. Re-install the engine cover using the original nuts removed in step #1.



33. Reconnect the mass air sensor electrical connections.



34. Reconnect the negative battery cable and double check to make sure everything is tightened and properly positioned before starting the vehicle.

35. It will be necessary for all intakes to be checked periodically for realignment, clearance and tightening of all connections. Failure to follow the above instructions or proper maintenance may void warranty.

ROAD TESTING:

1. Start the engine with the transmission in neutral or park, and the parking brake engaged. Listen for air leaks or odd noises. For air leaks secure hoses and connections. For odd noises, find cause and repair before proceeding. This kit will function identically to the factory system except for being louder and much more responsive.

2. Test drive the vehicle. Listen for odd noises or rattles and fix as necessary.

3. If road test is fine, you can now enjoy the added power and performance from your kit.

4. K&N suggests checking the Filtercharger element periodically for excessive dirt build-up. When the element becomes covered in dirt (or once a year), service it according to the instructions on the Recharger service kit, part number 99-5050 or 99-5000.